

Electronic Jet Kit™ Instructions



Thank you for choosing the Techlusion Electronic Jet Kit, the TFI. The TFI is only usable for the following Harley Davidson models:

- 2006 DYNA **“ONLY”**

This product is a great fit for stock bikes with exhaust and intake mods.

This is an Electronic Jet Kit. Like jet kits in the past, the more you modify, the more responsibility you take in getting your fuel curve right. Going to www.dobeckperformance.com will help you obtain better high horsepower tuning.

INSTALLATION PREP

- Install Time: 60 minutes
- Required Tools for: Disconnecting the negative terminal of the battery
Removing your seat
Loosening and propping up the fuel tank

Some vehicle modifications with Techlusion Inc. products must not be used on public roads and in some cases may be restricted to close course competition. Those products not identified as US EPA legal are intended for off-road or marine applications only. Not intended for use ON emission controlled vehicles.

Electronic Jet Kit™ Instructions



1. Before installing the TFI you must first disconnect the negative lead from the battery.
2. Determine a location for the TFI unit. Suggested locations are as follows:
DYNA – see figure 2 - Under seat, inside large frame opening
3. Make sure your motorcycle is cold, locate and disconnect the fuel line under the left hand side of the fuel tank using the quick disconnect feature on the fuel fitting (**DO NOT UNSCREW THE FITTING**). Remove the rear fuel tank mounting bolt and slowly lift up the fuel tank (make sure the fuel tank does not come in contact with steering area). You will need something to hold the fuel tank up (block of wood or a towel) from the frame to gain access to the injectors.
4. Underneath the fuel tank you will locate the fuel injectors (DYNA figure 5).
5. Disconnect the factory fuel injector connector from the fuel injector. Connect the TFI fuel injector harness inline with the factory fuel injector connector and the factory fuel injector.
Reference following figures: (DYNA- figures 6,7,8)
IMPORTANT: The TFI injector harness with the white/yellow wires must go to the front cylinder. The TFI injector harness with the green/gray wires must go to the rear cylinder.
We recommend the TFI injector harness run along the left side of the frame backbone to the injectors along with the front TFI O2 harness (long harness with pink/tan wires).
IMPORTANT: Make sure all connections are firmly secure and allow a little slack at the connections to prevent engine vibration from damaging/breaking a wire on the harness.
6. The front factory O2 connector is located in between the front down tubes of the frame just behind the front tire (DYNA figure 3). The front TFI O2 harness (long harness with pink/tan wires) will run along the left side of the frame down to the front factory O2 connector.
DYNA - O2 connector is actually located behind the voltage regulator assembly inside a plastic connector caddy attached to the backside of the voltage regulator. You will need to remove the voltage regulator to gain access to the plastic connector caddy and the factory front O2 connector.

Once you have gained access to the front factory O2 harness for your model, connect the front TFI O2 harness (long harness with pink/tan wires) inline with the factory O2 connector and secure.
IMPORTANT: Make sure connection is firmly secure and allow a little slack at the connection to prevent engine vibration from damaging/breaking a wire on the harness.
7. The rear factory O2 connector is located:
DYNA – figure 4 - Under the seat, inside the frame opening.
Once you have gained access to the factory rear O2 harness for your model, connect the rear TFI O2 harness (short harness with purple wires) inline with the factory O2 harness then secure.
IMPORTANT: Make sure connection is firmly secure and allow a little slack at the connection to prevent engine vibration from damaging/breaking a wire on the harness.
8. Replace the fuel tank (make sure all mounting bolts are in place and fuel connections are correct).
9. Connect the TFI ground lead to the negative terminal of the battery along with the factory ground lead.

Electronic Jet Kit™ Instructions



1. After connecting the box, check all wire connections to ensure proper connection. Do this by pulling on the connection to make sure the connectors are *properly locked in*.
2. Be sure to check the wire harnesses are not in direct contact with any sharp edges, exhaust and/or other objects, which could result in long term wear and/or damage.
3. Start the bike up. In approximately five seconds, the lights inside the TFI will energize and become visible. With a proper installation it will then stop scrolling the lights and go to a steady green light to the far left and "MAY" have a flashing blue light to the far right. With an improper installation the light display (while engine is running) will consist of a flashing green and a flashing red light. This occurs when the TFI is not receiving a proper injector signal. Recheck the wire connections for any defects. *(The flashing green and flashing red lights is common for a proper installation during deceleration because the stock fuel map shuts off the fuel injectors during this process.)*
4. At this point you are ready to adjust the TFI to the base settings supplied with the unit. The first thing to do is ensure the proper code was supplied by checking that the six programmable features are available. To begin this process press the MODE button and to enter each successive mode, just press the MODE button again. The unit comes with pre-programmed base settings, which should match the recommended starting settings on pg 8.
 - a. The **first mode** represents an additional amount of fuel added during light load steady throttle cruise/idle. A flashing **green light** should appear somewhere on the light display.
 - b. The **second mode** represents an additional amount of fuel added during acceleration. A flashing **yellow light** should appear somewhere on the light display.
 - c. The **third mode** represents an additional amount of fuel added during full throttle. A flashing **red light** should appear somewhere on the light display.
 - d. The **fourth mode** represents an adjustment for richening the de-acceleration fuel mixture. A flashing **green light** should appear somewhere on the light display along with a flashing **blue light** on the very right side.
 - e. The **fifth mode** represents an adjustment for when the yellow fuel engages. A flashing **yellow light** should appear somewhere on the light display along with a flashing **blue light** on the very right side.
 - f. The **sixth mode** represents an adjustment for when the red fuel engages. A flashing **red light** should appear somewhere on the light display along with a flashing **blue light** on the very right side.



Electronic Jet Kit™ Instructions

If each mode is present then the proper code exists and you are ready for making manual adjustments. If you failed to enter a mode, try going through the sequence again and be sure to only press the MODE button once in between each step.

5. You are now ready to manually program each mode. Consult the base settings supplied with the unit or you can look up the most up-to-date settings by going to www.dobeckperformance.com.

To program the TFI, the bike must be running in order to supply power to the box.

If at anytime you stay in an adjusting mode for longer than 5 seconds without pressing any buttons, the TFI will exit adjusting mode and will return to the ready state.

To save settings for a particular mode, press the MODE button which goes to the next adjustable mode or wait for the TFI to exit back to the ready state.

The settings are adjusted by pressing the PLUS and MINUS buttons located on the right and left side respectively of the MODE button. To start adjusting, first press the MODE button the desired amount of times to reach the mode you wish to adjust. Pressing the PLUS button signifies an increase of 0.5 for the mode setting. Similarly, pressing the MINUS button signifies a decrease of 0.5 for the mode setting. The range of settings for each mode is 0 to 8. Light settings of 0 or 0.5 are essentially the same and are displayed by the very left light blinking at a faster rate than normal. When entering into green/blue, yellow/blue, or red/blue modes, a flashing blue light will appear on the very right. For light settings of 7.5 and 8 within these modes, the very right light will flash back and forth between the respective mode's color and blue. To see a visual display of adjusting settings go online to dobeckperformance.com

6. Your TFI should now be properly programmed and you are now ready to tune your bike.

Always make sure your bike is at normal operating temperature when making tuning adjustments.

Electronic Jet Kit™ Instructions



Tuning for mode 1 – Fuel addition during steady throttle cruise/idle.

This adjustment deals with adding fuel during all steady throttle/idle conditions. The lowest light setting (0) represents the factory fuel addition level and the highest light setting (8) represents the maximum amount of TFI fuel added to the factory level.

Tuning for mode 2 – Fuel addition during acceleration

Tuning for this mode depends greatly upon your individual bike and can vary widely from the base setting. After market high flow exhaust systems and high flow air filters “MAY” cause you to tune differently from the base settings. This combination could have a setting difference as great as three yellow lights. Note that this adjustment is only for hard acceleration. The lowest light setting (0) represents the factory fuel addition level and the highest light setting (8) represents the maximum amount of TFI fuel added to the factory level.

Tuning for mode 3 – Fuel addition during full throttle

This adjustment deals with adding fuel for primarily 4000 RPM and up to red line. For example, running to red line in 1st, shifting, running to red line in 2nd, shifting, and continuing this all the way through the gear range, you would have been engaging the red light all the time. Again this mode could vary widely from the base settings depending on the set up of your bike and could have a difference as great as three red lights or more. The lowest light setting (0) represents the factory fuel addition level and the highest light setting (8) represents the maximum amount of TFI fuel added to the factory level.

Tuning for mode 4 – Represents an adjustment for richening the de-acceleration mixture

This adjustment deals with enrichening the de-acceleration fuel. The lowest light setting (0) represents the factory fuel addition level and the highest light setting (8) represents the maximum amount of TFI fuel added to the factory level.

Tuning for mode 5 – Represents an adjustment for when the yellow fuel engages

This mode “MAY” vary from the base settings depending on the set up of your bike. The lowest light setting (0) represents the lightest load to switch on the yellow fuel and the highest light setting (8) represents the heaviest load to switch on the yellow fuel.

Tuning for mode 6 – Represents an adjustment for when the red fuel engages

The base setting for this mode will rarely have to be changed. The red light should be engaged during the full throttle period. For example, running to red line in 1st, shifting, running to red line in 2nd, shifting, and continuing this all the way through the gear range, the red light should be engaged the whole time. If you do not see the red light the whole time then you need to lower this setting to make the red light turn on sooner.



Electronic Jet Kit™ Instructions

TFI Instructions

General Layout

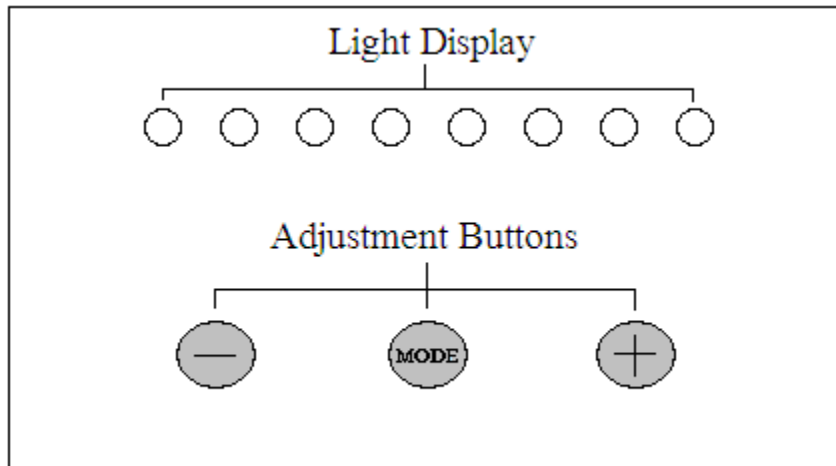

Start-Up Light Sequence

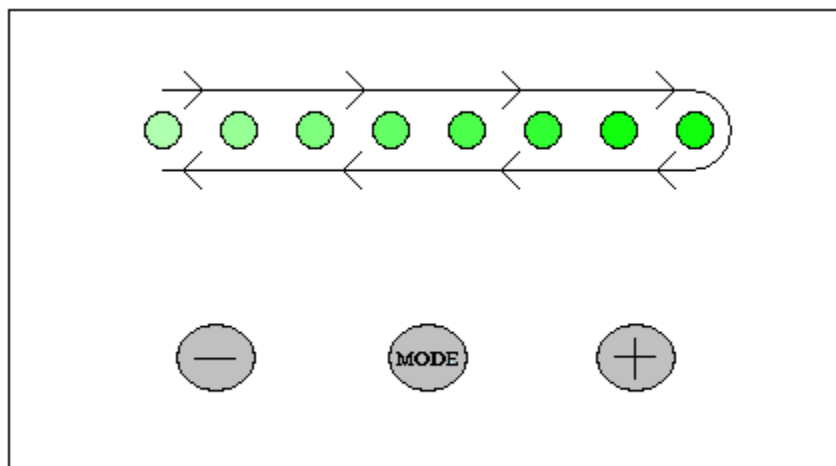



Electronic Jet Kit™ Instructions

Adjustment Modes

Mode 1 – Green

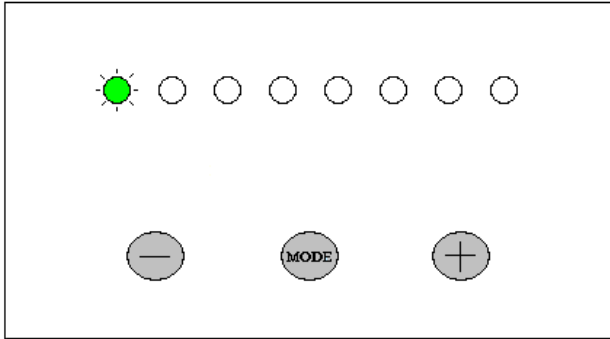

Mode 2 – Yellow

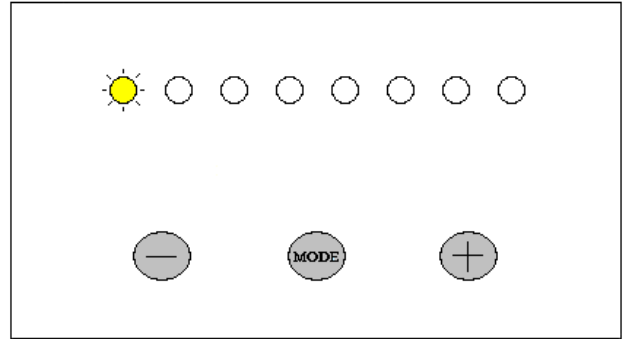

Mode 3 – Red

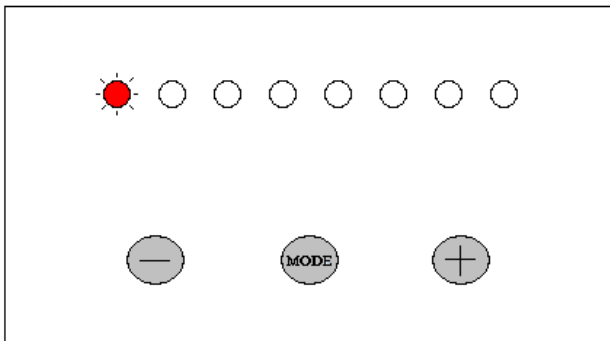

Mode 4 – Green/ Blue

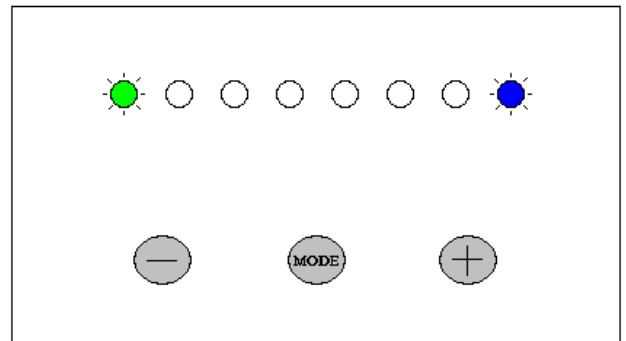

Mode 5 – Yellow/Blue

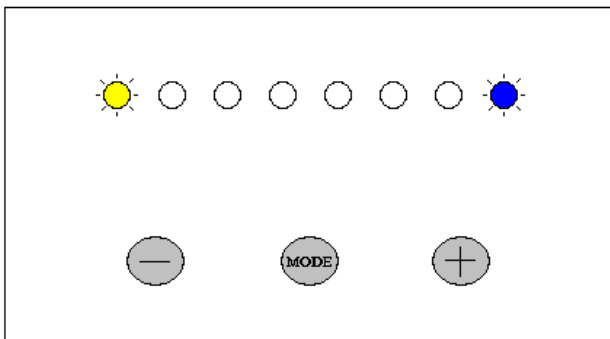

Mode 6- Red/Blue

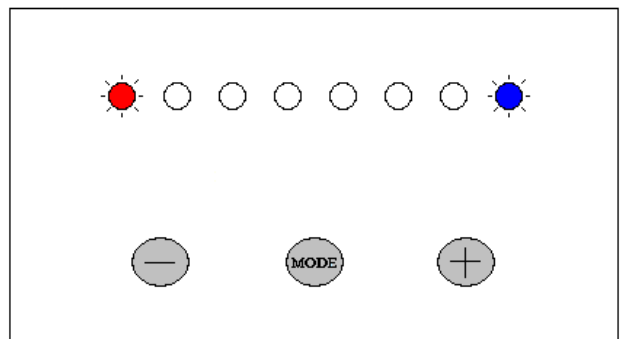



Electronic Jet Kit™ Instructions

'06 Dyna Base Settings

Mode 1

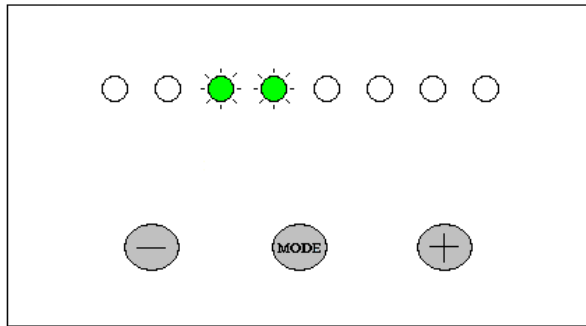

Mode 2

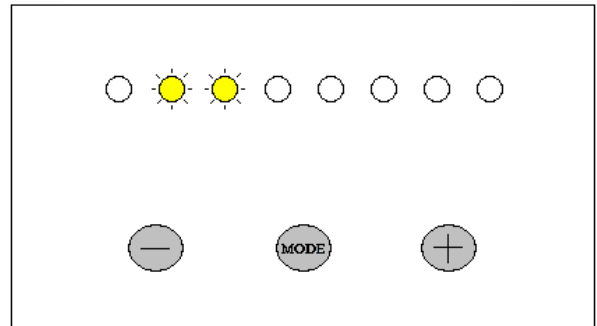

Mode 3

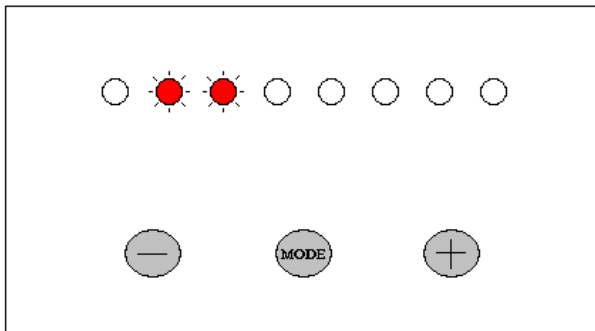

Mode 4

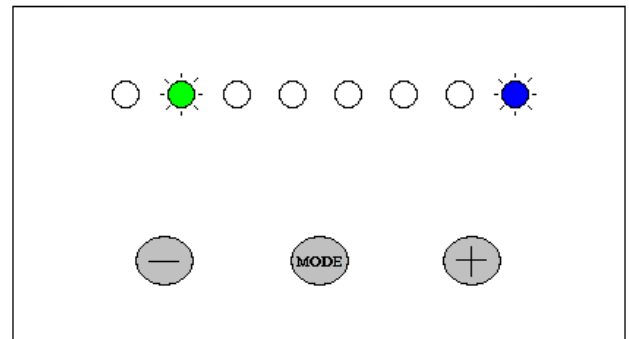

Mode 5

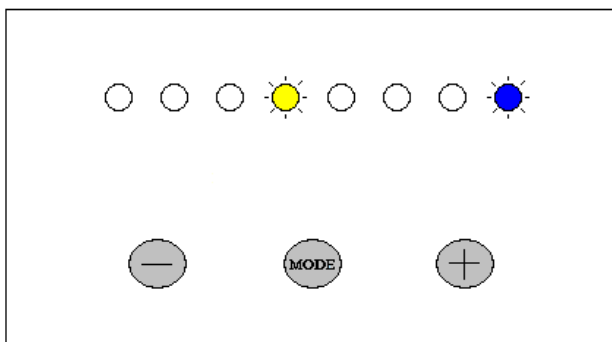

Mode 6

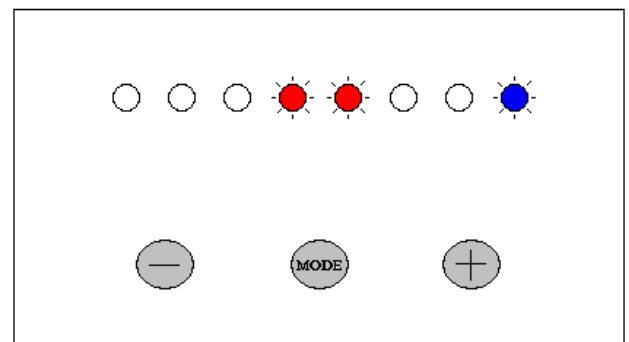



Electronic Jet Kit™ Instructions

'06 Dyna Stage 1

Mode 1

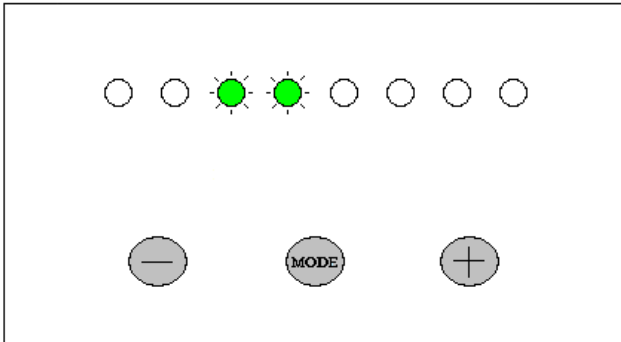

Mode 2

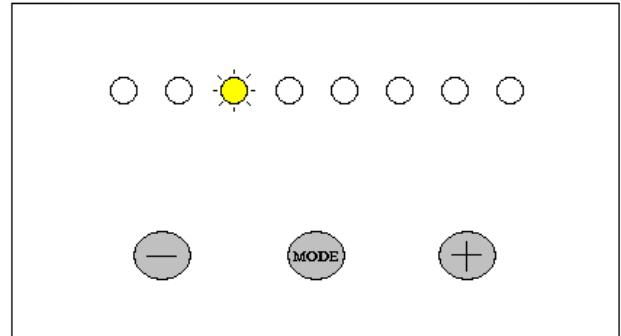

Mode 3

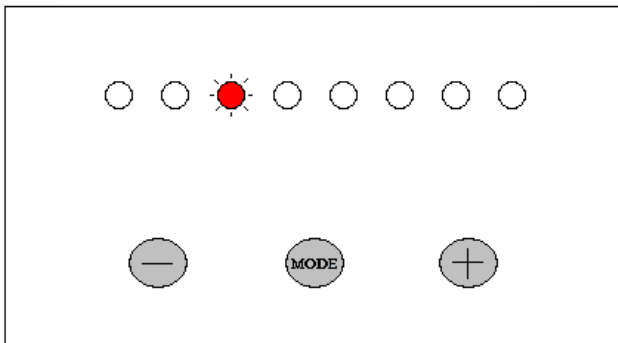

Mode 4

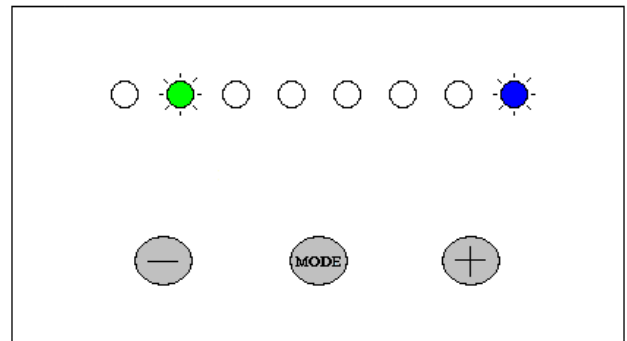

Mode 5

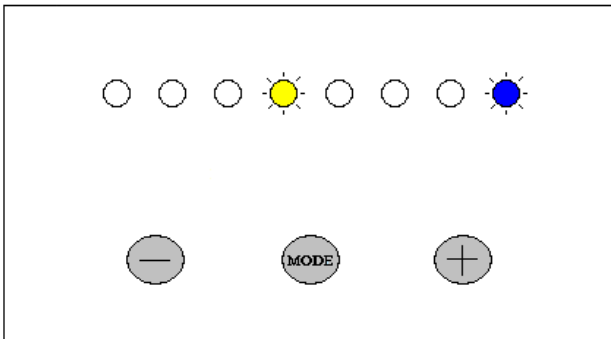

Mode 6

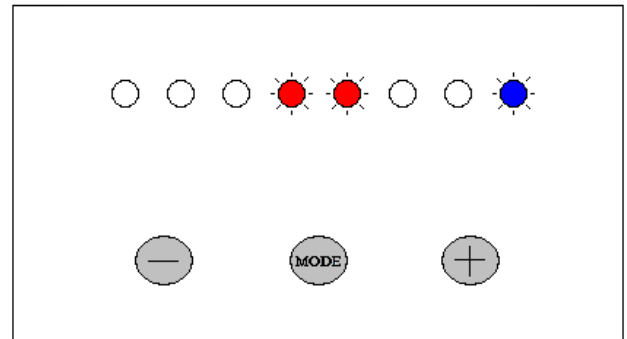



Electronic Jet Kit™ Instructions

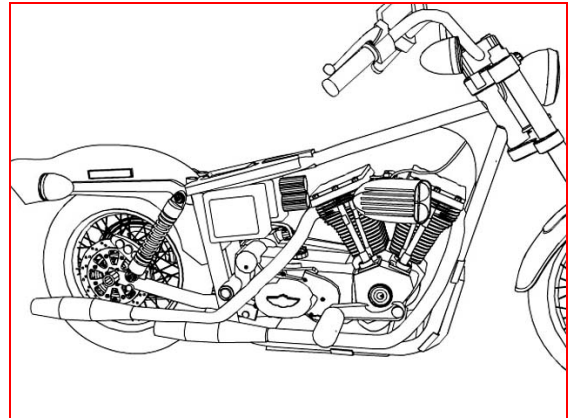
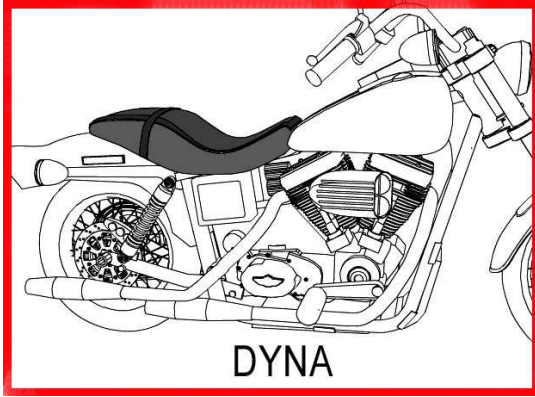

Figure 1

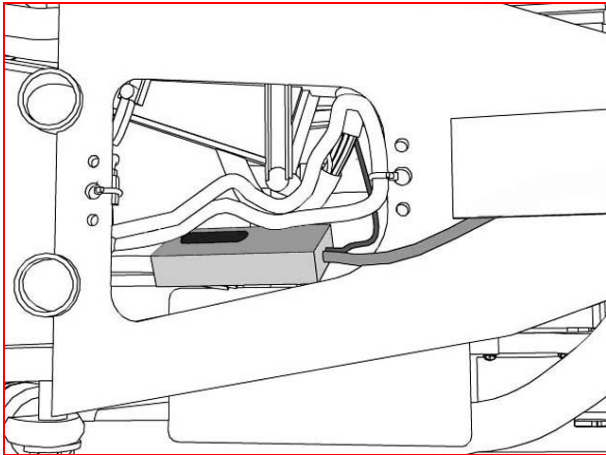

Figure 2

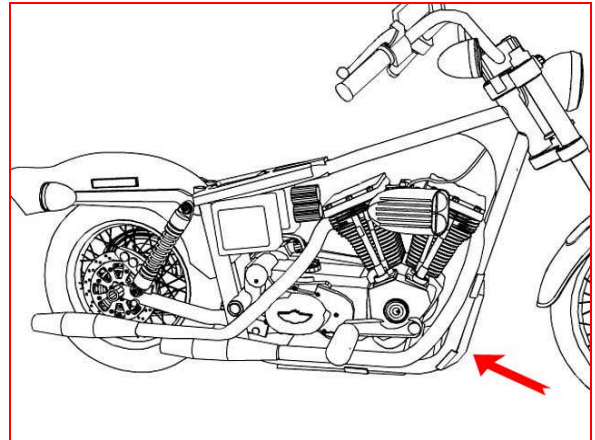

Figure 3

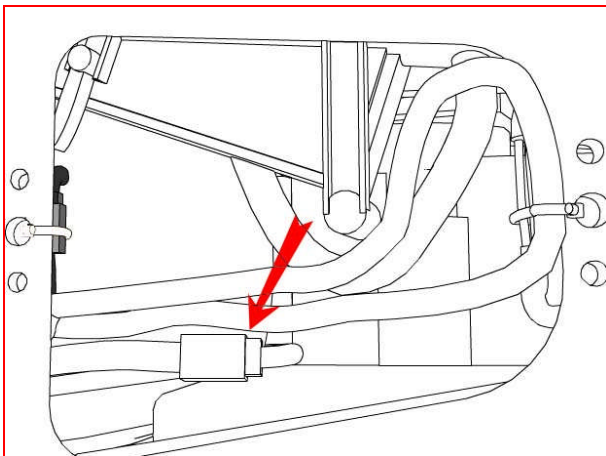

Figure 4

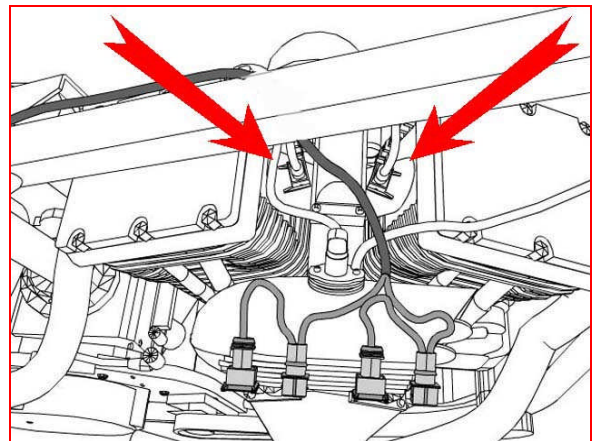

Figure 5



Electronic Jet Kit™ Instructions

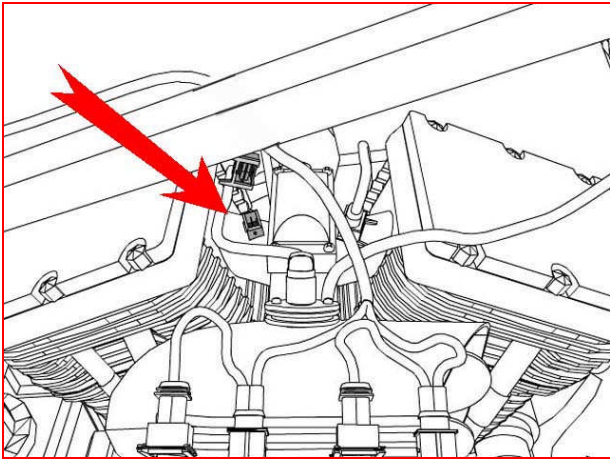

Figure 6

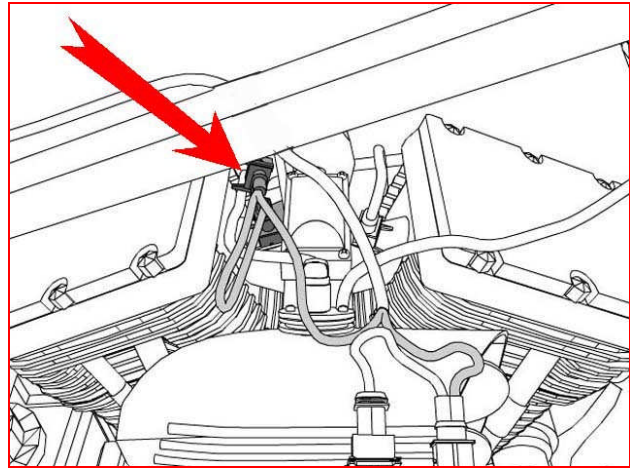

Figure 7

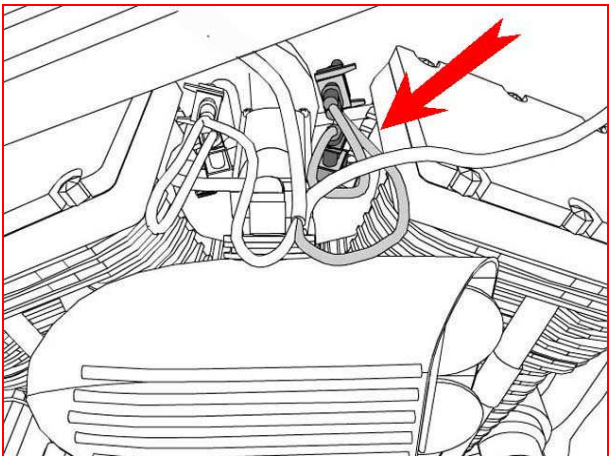

Figure 8

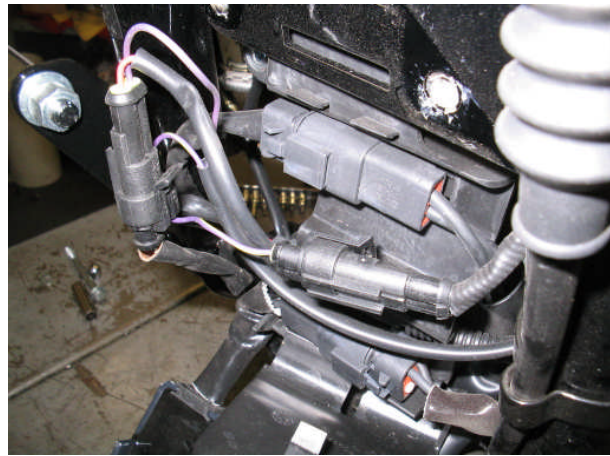

Figure 9

Electronic Jet Kit™ Instructions



2-year Unlimited Mileage Warranty

Techlusion warrants that this product carries a warranty for 2-years from date of purchase against original defects in materials and workmanship. Should this product fail to perform for either of the above reasons, Techlusion will repair or replace it with an equivalent product at no charge, except for postage, to the original retail purchaser.

*****IMPORTANT*****

To obtain the benefits of this warranty, the retail purchaser must first call 1-877-764-3337 to obtain a Return Authorization Number, then send the product with proof of purchase and postage prepaid to:

**Dobeck Performance
157 Progressive Dr.
Belgrade, MT 59714**